

WATERCO SKIMMER BOXES

Operating Instructions (See over for Installation Tips)

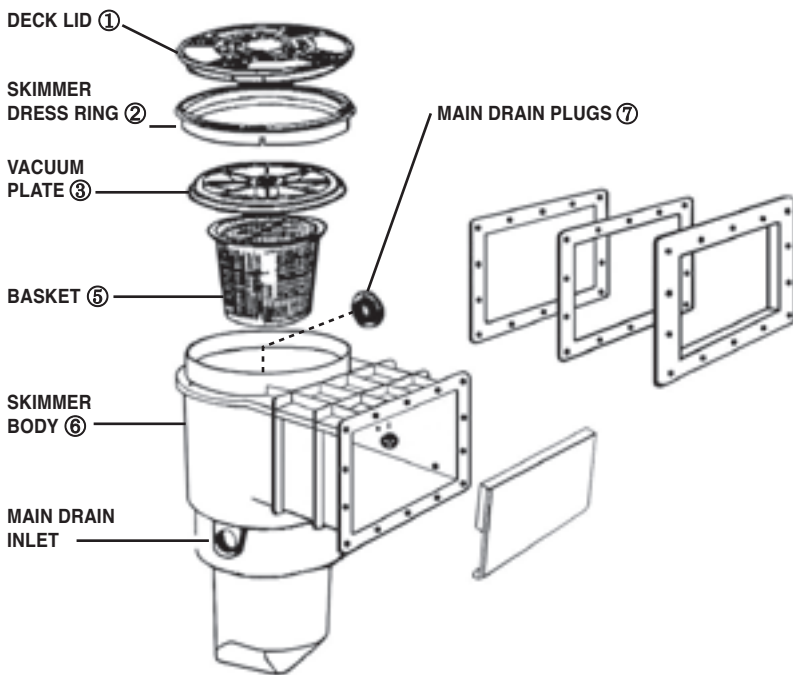

* Figure 1: S75 MK2 and Supaskimmer Skimmer Boxes

■ TO REMOVE DECK LID

Turn the Deck Lid ① anti-clockwise until it stops. This will align the lugs on the lid with the recesses on the Dress Ring ②. Lift up.

■ TO RE-INSERT DECK LID

Align the lugs on the underside of the Deck Lid ① with the recesses in the Dress Ring ②. The lid should sit flush with the Dress Ring. Turn the lid clockwise until it stops. This will "lock" the lid in place. The lid may then be secured in place with two screws.

■ TO REMOVE SKIMMER BASKET

With the pump OFF, grip the brass handle and turn the basket ⑤ a quarter turn anti-clockwise. This will align the recesses on the basket with the lugs on the skimmer body ⑥. Lift up.

■ TO RE-INSERT SKIMMER BASKET

With the pump off, locate the recesses on the basket ⑤ with the lugs on the skimmer body ⑥, making sure that when the basket is turned a quarter turn clockwise the opening in the basket will align with the opening to the main drain in the skimmer. Push down and turn.

■ TO VACUUM

S75 MK2 and Supaskimmer: With the pump OFF, screw the main drain plug(s) ⑦ into the main drain inlet(s) in the skimmer body ⑥. Fit the vacuum plate ③ to the skimmer body above the basket ⑤ by locating cut outs on the vacuum plate with the lugs inside the skimmer body. Push down and turn a quarter turn clockwise. This will lock the vacuum plate into position.

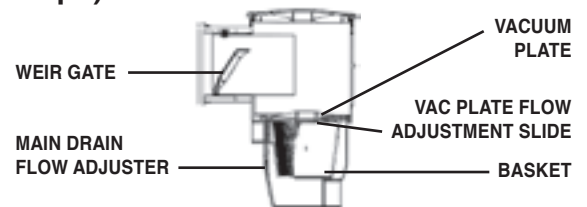

* Figure 2: SP5000 Skimmer Box (side view)

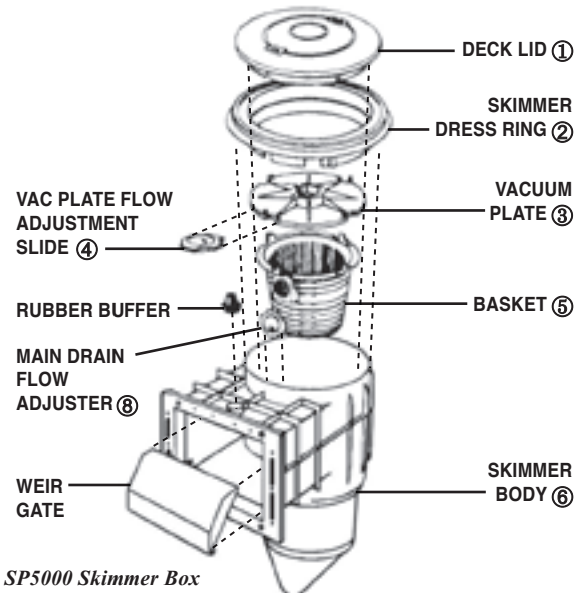

* Figure 3: SP5000 Skimmer Box

SP5000: With the pump OFF, slide up and close the main drain flow adjuster ⑧. Slide along and open the vacuum plate flow adjuster ④ on the underside of the vacuum plate ③. Fit the vacuum plate to the top of the basket ⑤ by locating the cut outs in the vacuum plate with the lugs on the basket. Push down and turn clockwise a quarter turn. This will lock the plate into position.

■ TO REMOVE VACUUM PLATE

With the pump OFF, turn the vacuum plate ③ a quarter turn anti-clockwise, Lift up.

NB: The vacuum plate should be left out of the skimmer box and the main ⑦ drain inlet(s)/ flow adjuster should be open during day to day running.

■ TO DRAW FROM MAIN DRAIN ONLY

S75 MK2 and Supaskimmer: Remove the main drain plug(s) ⑦ from the main drain inlet(s) in the skimmer body ⑥. Fit the vacuum plate to the skimmer box as before. Plug the port in the vacuum plate with a standard 40mm (1 1/2") male threaded plug (not supplied).

SP5000: Slide to open the main drain flow adjuster ⑧. Slide to close the vacuum plate flow adjuster ④. Fit the vacuum plate ③ to skimmer box as before.

ATTENTION: THIS MANUAL MUST BE GIVEN TO THE OWNER / OPERATOR OF THIS EQUIPMENT

See over for Installation Tips

Installation Tips for Skimmer Boxes

■ Fibreglass/ Vinyl Lined Pools

- Top of skimmer box MUST be horizontal.
- Top of the skimmer box mouth MUST be at least 75mm below the top of the pool wall.
- Ground surrounding the skimmer box MUST be properly filled in and packed so the skimmer box is not squeezed into an oval shape by the surrounding ground. Using a bobcat for this purpose is NOT recommended.

■ Concrete Pools

- Top of skimmer box MUST be horizontal.
- Extension Rings (available separately).
- Concrete surrounding the skimmer box MUST be properly reinforced.

If the Skimmer box is to be installed with the Dress Ring above and unsecured to the Skimmer Body, Waterco recommends the use of an Extension Ring.

Extension Ring (60mm Prod No: 624105) Sold Separately

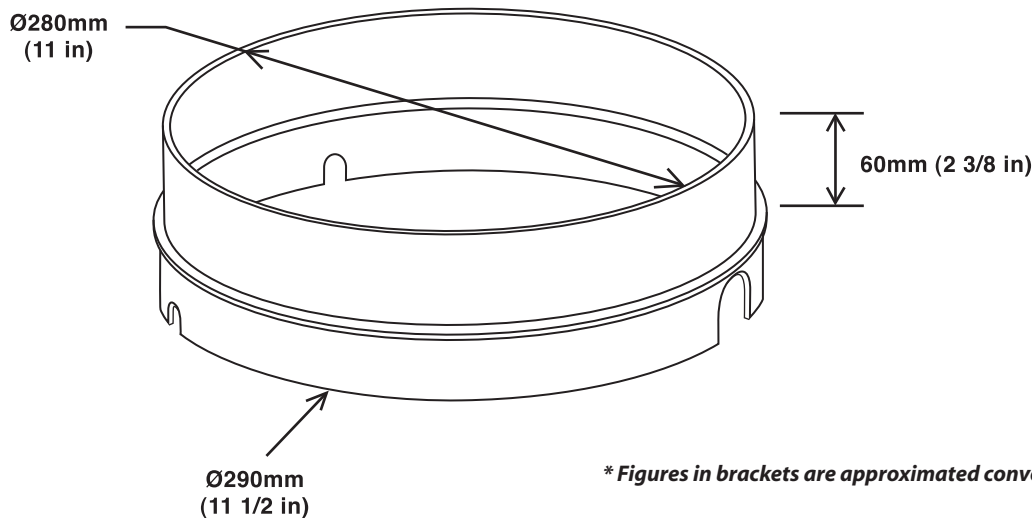

** Figures in brackets are approximated conversions*

The Waterco Extension Ring sits snugly on top of the skimmer box between the skimmer box body and the Dress Ring.

- Suits the Supaskimmer, S75 MK2 Skimmer and the Automatic Water Leveller MKII.
- Prevents the misalignment of the Dress Ring and the Skimmer Body.
- Ensures no difficulties inserting or removing the vacuum plate.
- Protects the Skimmer Box cavity from concrete intrusions.
- Provides a professional clean finish.

An individual Extension Ring offers an extension of 60mm and can be piggybacked to give an extension of any multiple of 60mm, e.g. 120mm, 180mm, 240mm...etc.

ATTENTION: THIS MANUAL MUST BE GIVEN TO THE OWNER / OPERATOR OF THIS EQUIPMENT

See over for Operating Instructions

WATERCO

water, the liquid of life

Waterco Limited ABN 62 002 070 733

OFFICES - AUSTRALIA

NSW - SYDNEY
(HEAD OFFICE)
Tel: +61 2 9898 8600

QLD - BRISBANE
Tel: +61 7 3299 9900

VIC/TAS - MELBOURNE
Tel: +61 3 9764 1211

WA - PERTH
Tel: +61 8 9273 1900

SA/NT - ADELAIDE
Tel: +61 8 8244 6000

ACT DISTRIBUTION
Tel: +61 2 6280 6476

OFFICES - OVERSEAS

WATERCO (EUROPE) LIMITED
Sittingbourne, Kent, UK
Tel: +44 (0) 1795 521 733

WATERCO FRANCE
Saint Priest, France
Tel: +33 4 72 79 33 30

WATERCO (USA) INC
Augusta, Georgia, USA
Tel: +1 706 793 7291

WATERCO CANADA
Longueuil, Quebec, Canada
Tel: +1 450 748 1421

WATERCO (NZ) LIMITED
Auckland, New Zealand
Tel: +64 9 525 7570

WATERCO © LIMITED
Guangzhou, China
Tel: +86 20 3222 2180

WATERCO (FAR EAST) SDN BHD
Selangor, Malaysia
Tel: +60 3 6145 6000

PT WATERCO INDONESIA
Jakarta, Indonesia
Tel: +62 21 4585 1481

WATERCO SINGAPORE INTL PTE LTD
Nehsons Building, Singapore
Tel: +65 6344 2378