

# microlene<sup>®</sup>

## 3 Way Mixer Tap Under Bench Filtration Systems

### Installation and Operating Instructions



MTC-HF1M (Chrome finish)  
and MTCM-HF1M (Matt finish)  
3 Way Mixer Tap and Under  
Bench Filtration Systems



HF1M  
High Flow Under  
Bench Filtration Kit



HF1M-R  
Replacement  
Cartridge

# DAVEY

Tested in compliance with  
**AS/NZS 4020**   
for use in contact with safe drinking water



**Warning: Microlene under bench system installation must be in compliance with all local legislative requirements, and installed by a licensed plumber.**

Please pass these instructions on to the operator of this equipment.

Congratulations on purchasing this three way mixer tap and/or under bench filtration system. By purchasing a Microlene Filtration System you are receiving not only a high quality product but also peace of mind. Protecting your water supply with a filtration system gives you reassurance that your family will have access to better tasting filtered drinking water through your designated outlet protecting them from taste, odour and contamination from unwanted fines in your water supply. Simple maintenance of your continuous filtration system will ensure good tasting water from your home's connected outlet, Microlene makes it that easy.

These instructions are also available in soft copy via email from Microlene Customer Service or on line at the Davey website: [daveywater.com](http://daveywater.com)

## TABLE OF CONTENTS

Specifications .....	4
Safety Considerations.....	4
Water Quality Parameters .....	4
Kit Components .....	5
Installation .....	8
3 Way Mixer Tap and Under Bench Filtration Systems .....	14
High Flow Under Bench Filtration System.....	14
Replacing the Filtration Cartridge .....	15
System Troubleshooting .....	16
Warranty.....	19

## Specifications

- **Max pressure rating:** 200 - 680kPa
- **Water temperature:** 0 - 38°C
- **Micron rating:** 1 micron
- **Flow rate:** 9.5 lpm
- **Cartridge capacity:** 65,000 lpm
- **Cartridge replacement:** 6 monthly
- **Replacement cartridge:** HF1M-R

## Mounting

- **Vertical:** 500mm (h) x 215mm (w)
- **Horizontal:** 215mm (h) x 500mm (w)
- **Required hole for tap:** 33mm (on MTC-HF1M or MTCM-HF1M)

## Safety Considerations

1. The appliance is intended to be permanently connected to the water mains and not connected by a hose-set.
2. Maximum operating pressure for the system is 680kPa (98psi) - subject to regulatory limits.
3. Minimum operating pressure is 200kPa (29psi).
4. Water temperature range is 0 to 38°C. Do not operate with water below or above this range.
5. Do not use this system for any purpose other than what it was intended for. Misuse of this system could potentially cause harm to the user or others.
6. We recommend that a licensed plumber or certified technician install the system. In many areas this is a legislated requirement.

## Water Quality Parameters

The Microlene HF1M-R purification cartridge used in MTC-HF1M, MTCM-HF1M and HF1M is designed to purify and filter household drinking water only.

The HF1M-R cartridge can be used on both mains water (sanitised) as well as rains water. For use with Rain water the water coming into the house supply must have first been pretreated with 20 micron Poly Pleated Sediment cartridge then a 1 micron Poly Spun and finally UV treatment in order to remove large sediment, cysts (e.g. Giardia or cryptosporidium), viruses, bacteria and algae.

## System Components







MTC-HF1M (Chrome Finish Tap) and MTCM-HF1M (Chrome Matt Finish Tap) systems come in two cartons each:





Carton one contains the 3 way mixer tap and fittings.

Carton two labeled "HF1M" contains the filter cartridge system and braided hoses and brass connections. This carton is also sold separately as HF1M.

Note: When installing MTC-HF1M, MTCM-HF1M and HF1M some parts included in the carton may not be required.

**Carton One:**

<b>Component #</b>	<b>Description</b>	<b>Quantity</b>	<b>Picture</b>
1	Mixer tap (chrome or matt finish as applicable) with three 1/2" flexible hoses	1	
2	Connector (1/2" male thread x G1/4" tube)	1	
3	Tap base ring - Stainless steel	1	
4	Washers (small & large)	2	
5	Plastic gasket	1	
6	Horseshoe sealing gasket	1	

7	Retainer screw - long thread	2	
8	Retainer screw - brass nut	2	
9	Pressure limiting valve	1	
10	Connector to tube (filter x G1/4" tube)	2	
11	Smart Tee (T piece, isolating valve and back flow valve)	1	
12	Flexible plastic 1/4' tubing (Total 2 metres)	1	

**Carton Two (or HF1M when sold separately):**

Component #	Description	Quantity	Picture
13	1/2" Non return valve	1	
14	1/2" braided hose 450mm long	3	
15	1/2" MXF Brass adaptor	1	
16	Filter assembly including mounting bracket / connection head, cartridge and mounting screws	1	
17	1/2" Brass nipple	2	
18	Instruction and Operating Instructions	1	
19	Thread tape (1m)	1	

## Installation

### MTC-HF1M and MTCM-HF1M

3 Way Mixer Tap (carton one) with High Flow Under Bench Cartridge (carton two).

General tap layout

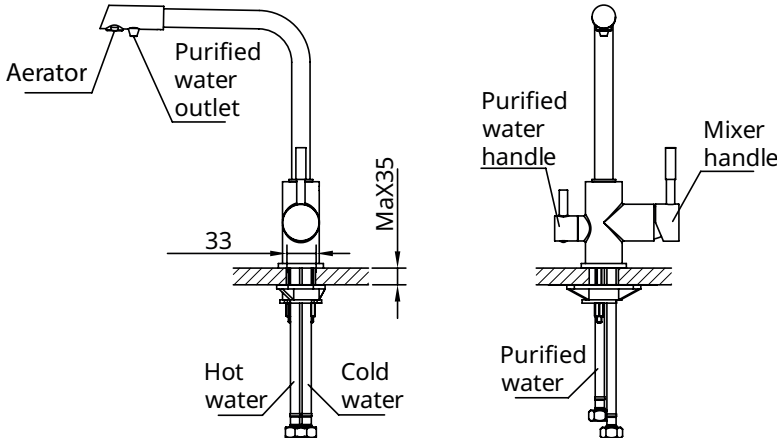

### Mixer water handle

1. Raise the lever handle to turn on the water. Push down to stop.
2. Turn the handle lever to the left to increase hot water flow, turn to the right for cooler water.

### Purified water handle

Turn the purified water handle clockwise to open purified water, the more you turn, the large flow rate. To close or reduce the flow rate, turn opposite way.

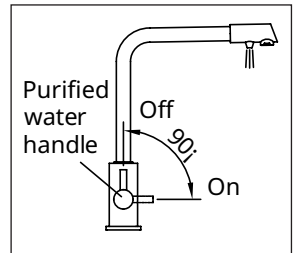
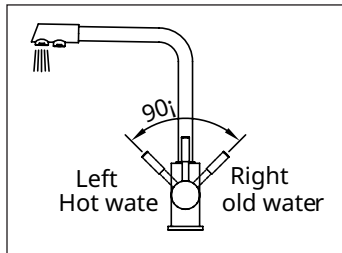
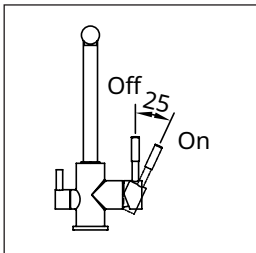

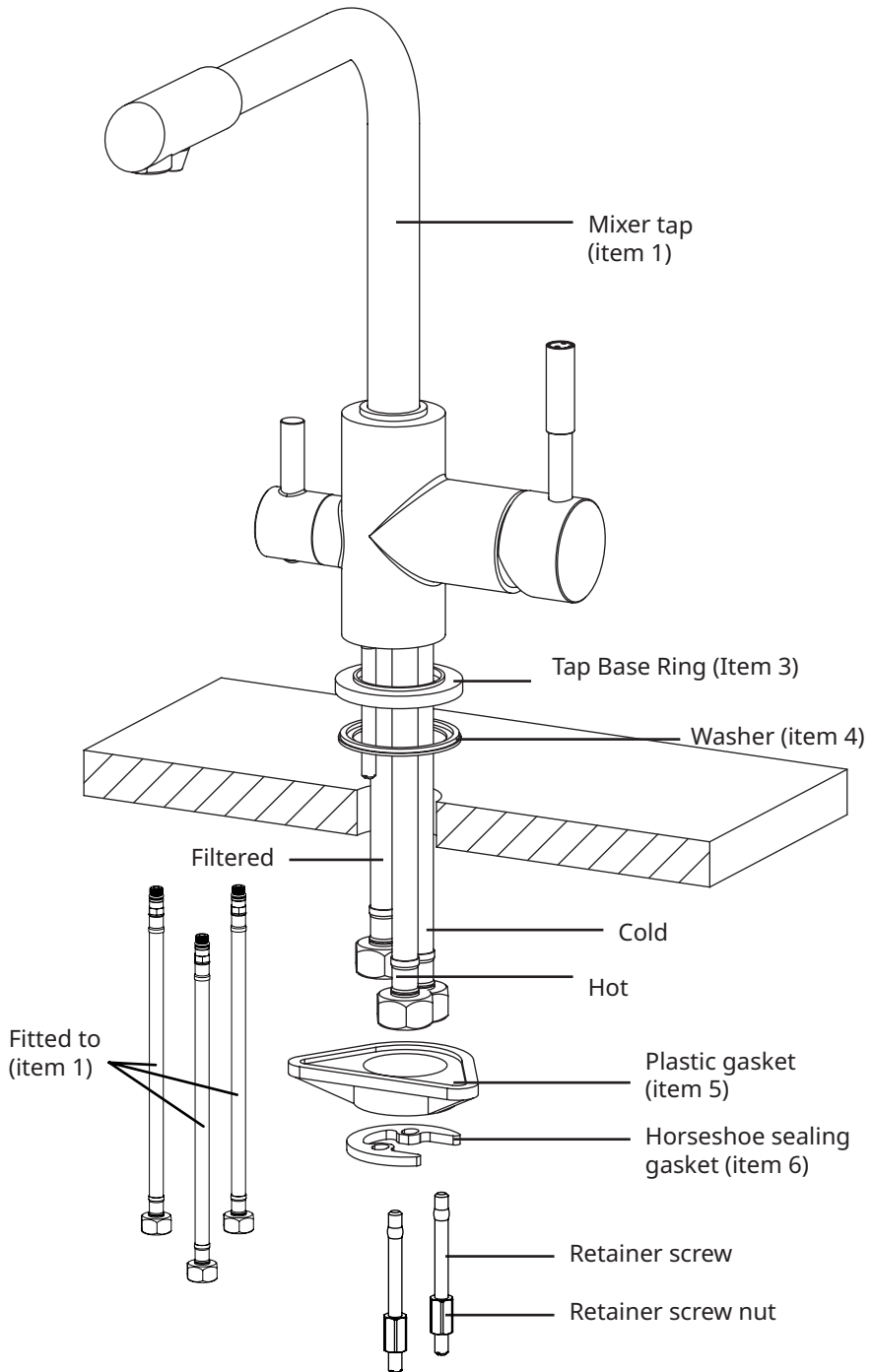



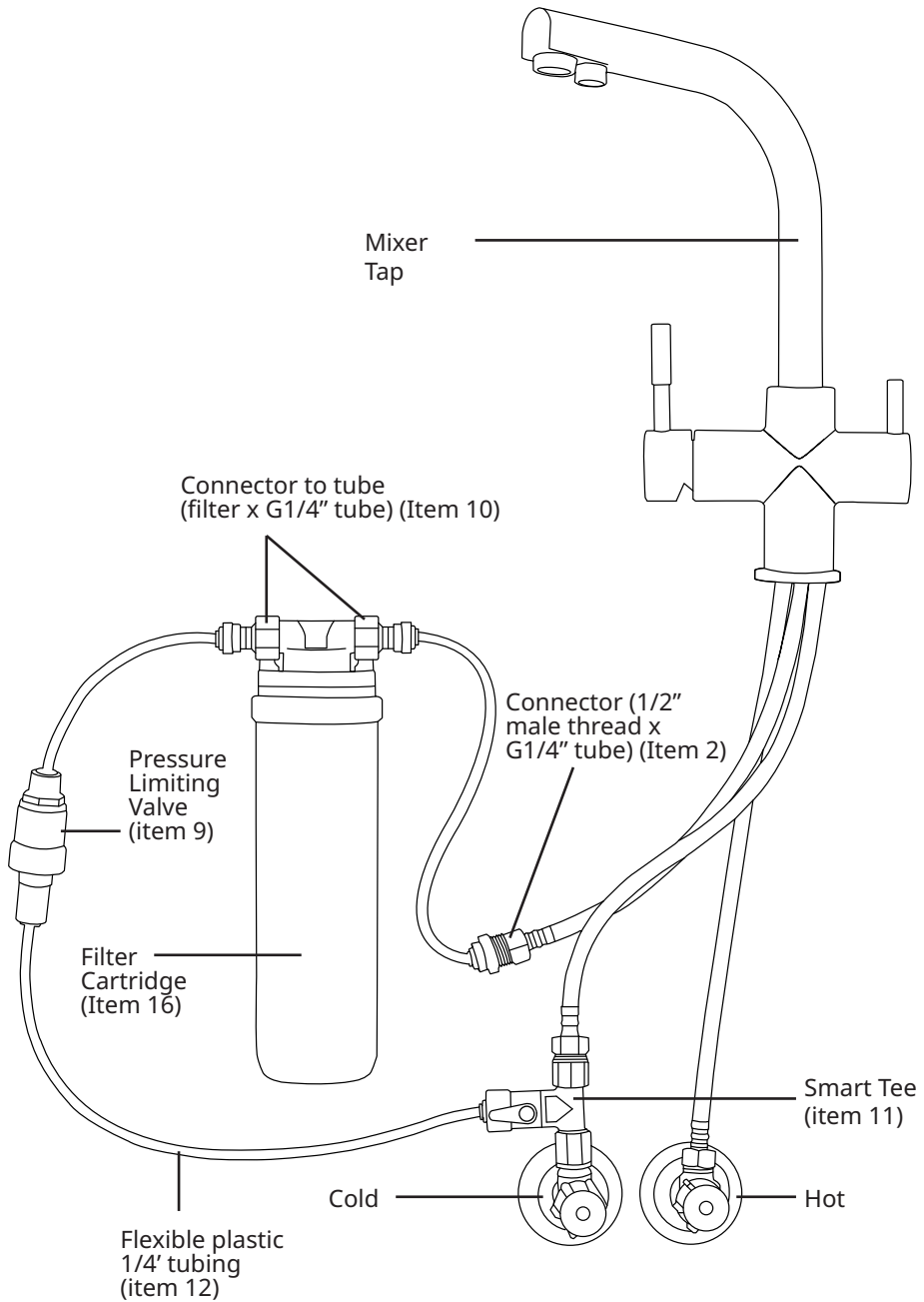

Mixer Tap

Connector to tube (filter x G1/4" tube) (Item 10)

Connector (1/2" male thread x G1/4" tube) (Item 2)

Pressure Limiting Valve (item 9)

Filter Cartridge (Item 16)

Smart Tee (item 11)

Cold

Hot

Flexible plastic 1/4" tubing (item 12)

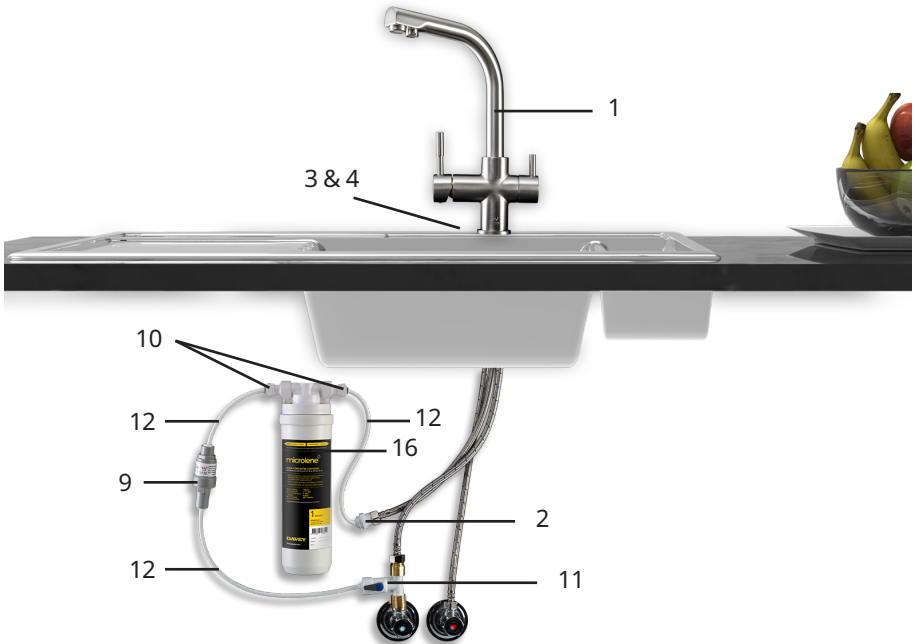

## NOTE:

Where the filter assembly is required to be mounted further than directly below the sink additional lengths of item 14 (1/2" braided hose 450mm long) joined using item 17 ( 1/2" brass nipple) can be attached to the braided filtered water line and then to the mixer tap.

## Installation Procedures:

**NOTE:** All male pipe threads must have adequate thread tape affixed for correct sealing.

1. Ensure all parts and tools required are ready for use.
2. Turn off water supply and relieve pressure in old tap fixtures if applicable.
3. The hoses come preconnected to the tap. Check they are all hand tight - only use hand tightening to screw the flexible hoses. Do not over tighten. Don't use any tools.
4. Unscrew the Retainer Screw Nuts (item 8) from the Retainer Screws (item 7).
5. Insert the Retainer Screws (item 7) into the bottom of the tap - beside the hose entries - leaving screwdriver slot exposed.

6. Using a flat head screwdriver tighten the Retainer Screws into the bottom of the tap
7. The tap fits through a 33mm diameter hole. Ensure the hole is correctly positioned to allow the tap to discharge into the sink correctly.
8. Slide the stainless steel tap base ring (item 3) followed by the large washer (item 4) over the three hoses one at a time. Ensure both ring and washer are the correct way around – see below:

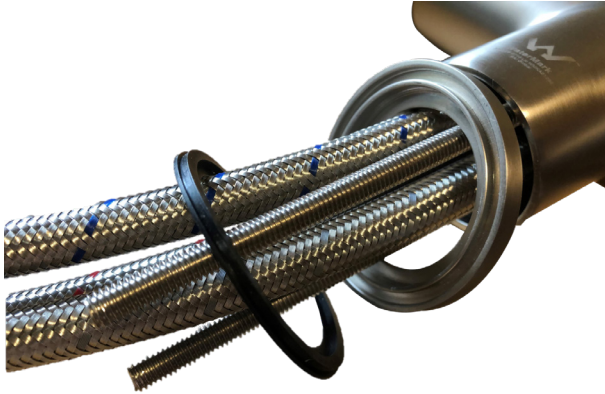

9. Slide hoses through hole in sink or bench as applicable
10. With the tap in place and correctly orientated, fit the plastic gasket first (item 5) with the larger flat surface facing the bottom of the sink or bench. Then slide the small rubber gasket (item 4) and then Horseshoe Sealing Gasket (item 6) which fits over the two retainer screws.
11. Fasten the retainer Screw Nuts onto the Retainer Screws and tighten using a 13mm spanner (Note: A box spanner is ideally suited)

## **Filter cartridge assembly and water supply**

1. Connect the hot water hose (red band) to the hot water supply.
2. Fit the Smart Tee (Item 11) to the cold water supply using the brass adaptor (item 15).
3. Connect the cold water hose to the straight through outlet. Water to the filter will go out via the Smart Tee (Item 11).
4. Fit the two Connectors to tube (filter x G1/4" tube) (Item 10) to the inlet and outlet on the Filter Assembly (Item 16)
5. Fit the Filter Assembly in a convenient position leaving at least 40mm clear below the filter housing to allow for filter cartridge swap over. Note the direction of flow arrow on top of the mounting bracket – in on the left and out on the right.
6. Fit the Connector (1/2" male thread x G1/4" tube) – (Item 2) to the filtered water braided hose.
7. Connect the Smart Tee using a length of 1/4" tube to the pressure limiting valve first ( Item 9 – Filter Protection Valve), noting direction arrow.
8. Continue tube line to the filter assembly, then onto the filtered water connection (step 6 above) on the braided hose.
9. Pressure test all connections and check for leaks. Rectify if needed.

# Installation

## HF1M

High Flow Under Bench Filtration System for plumbing into existing tap.

### Installation Procedures:

**NOTE:** All male pipe threads must have adequate thread tape affixed for correct sealing.

1. Ensure all parts and tools required are ready for use.
2. Turn off water supply and relieve pressure in old tap fixtures if applicable.
3. Disconnect the existing cold water connection hose from the cold water isolation valve under the sink. Note: In older systems where hard plumbing is used, the installing plumber may need to add an isolation valve, etc.
4. Connect the 1/2" Non return valve (item 13) to the cold water isolation valve. Ensure the 1/2" Non return valve is installed in the correct direction of flow – female thread in and male thread out.
5. To the male outlet thread on the 1/2" Non return valve (item 13) connect a 1/2" braided hose 450mm long (item 14)

**NOTE:** Where the filter assembly is required to be mounted further than directly below the sink additional lengths of 1/2" braided hose 450mm long (item 14) joined using item 17 ( 1/2" brass nipple) can be attached to the braided filtered water line and then to the mixer tap.

6. Fit the Filter Assembly in a convenient position leaving at least 40mm below the filter housing to allow for filter swap over. Note the direction of flow arrow on top of the mounting bracket – in on the left and out on the right.
7. Connect the hose as fitted in step 5 above to the inlet of the filter assembly.
8. Connect a second 1/2" braided hose 450mm long (item 14) to the outlet of the Filter Assembly.
9. Connect the other end of the second 1/2" braided hose 450mm long (item 14) to the cold water line on the sink tap.
10. Pressure test all connections and check for leaks. Rectify if needed.

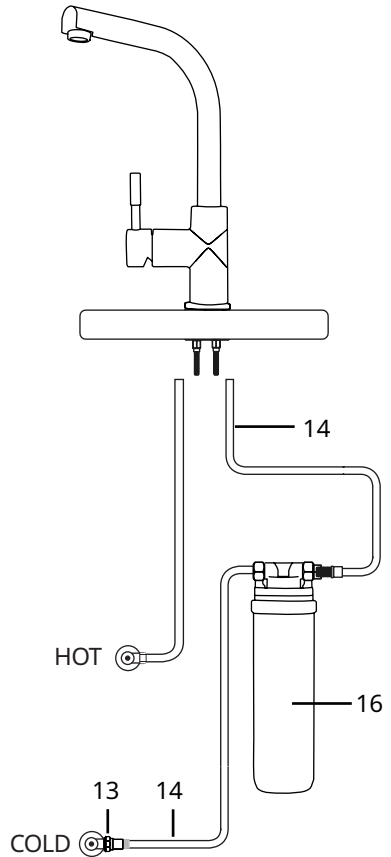

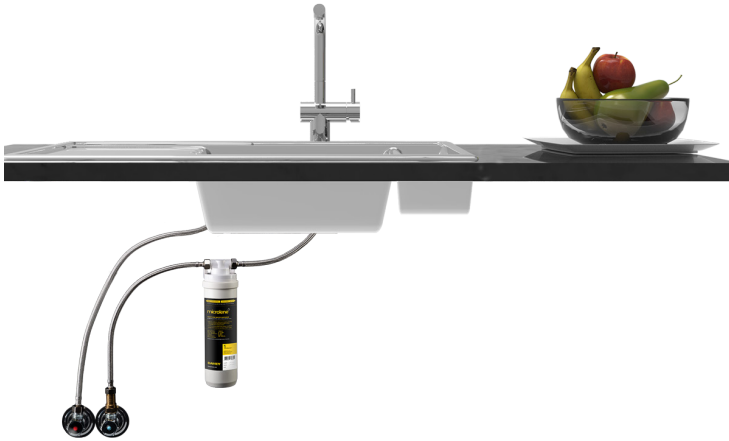

## Replacing The Filtration Cartridge (HF1M-R)

Depending on the incoming water quality the filter cartridge will need periodic replacement. In any case, to maintain safe operation, a new cartridge should be installed when any of the following occur:

- 6 months since installation or last cartridge change
- Flow rate through the cartridge slows to unserviceable levels
- Water tastes tainted

1. Turn off water supply to cold water line.
2. Relieve pressure from the applicable tap outlet (i.e. filtered water outlet for 3 way tap or cold water tap for high flow cartridge system).
3. Remove the old cartridge out of the mounting bracket/connection head. This is done by turning the cartridge clockwise when viewed down – see diagram below:

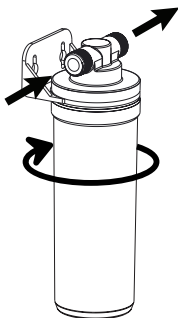

Note if unsure of correct direction of rotation there are arrows for ON (fit) and OFF (remove) at the base of the filter.

4. Install the new cartridge in the reverse tightening procedure. Once installed the colour label should face forwards towards the installer.
5. Turn on water supply and check for leaks. Rectify if needed.

## Troubleshooting

During usage there is little that can go wrong with your new system. The following items are easy to troubleshoot:

### **Water is not flowing from the outlet, or is flowing at low flow rates:**

- Inlet pressure too low
  - + Inlet pressure must be above 200kPa
- Cartridge blocked fully or partially
  - + Replace cartridge with new
  - + Consider pre-filters – consult your Microlene dealer
- Cartridge not installed correctly
  - + Remove and reinstall cartridge
- Pipework not installed correctly
  - + Review direction of flow on all valves and fittings to ensure they are installed in the correct direction

### **Water leaking:**

- Pipework not correctly assembled
  - + Review and/or reinstall pipework as required
- Cartridge not installed correctly
  - + Check sealing ring
  - + Check cartridge is tightened into mounting bracket/connection head correctly

If you are experiencing other issues contact your Microlene dealer for further advice.

# Davey Warranty

Davey Water Products Pty Ltd (Davey) warrants all products sold will be (under normal use and service) free of defects in material and workmanship for a minimum period of one (1) year from the date of original purchase by the customer as marked on the invoice, for specific warranty periods for all Davey products visit [daveywater.com](http://daveywater.com).

This warranty does not cover normal wear and tear or apply to a product that has:

- been subject to misuse, neglect, negligence, damage or accident
- been used, operated or maintained other than in accordance with Davey's instructions
- not been installed in accordance with the Installation Instructions or by suitably qualified personnel
- been modified or altered from original specifications or in any way not approved by Davey
- had repairs attempted or made by other than Davey or its authorised dealers
- been subject to abnormal conditions such as incorrect voltage supply, lightning or high voltage spikes, or damages from electrolytic action, cavitation, sand, corrosive, saline or abrasive liquids,

The Davey warranty does not cover replacement of any product consumables or defects in products and components that have been supplied to Davey by third parties (however Davey will provide reasonable assistance to obtain the benefit of any third-party warranty).

To make a warranty claim:

- If the product is suspected of being defective, stop using it and contact the original place of purchase. Alternatively, phone Davey Customer Service or send a letter to Davey as per the contact details below
- Provide evidence or proof of date of original purchase
- If requested, return the product and/or provide further information with respect to the claim. Returning the product to the place of purchase is at your cost and is your responsibility.
- The warranty claim will be assessed by Davey on the basis of their product knowledge and reasonable judgement and will be accepted if:
  - a relevant defect is found
  - the warranty claim is made during the relevant warranty period; and
  - none of the excluded conditions listed above apply
- The customer will be notified of the warranty decision in writing and if found to be invalid the customer must organise collection of the product at their expense or authorise its disposal.

If the claim is found to be valid Davey will, at its option, repair or replace the product free of charge.

The Davey warranty is in addition to rights provided by local consumer law. You are entitled to a replacement or refund for a major failure and compensation for any other reasonably foreseeable loss or damage. You are also entitled to have the goods repaired or replaced if the goods fail to be of acceptable quality and the failure does not amount to a major failure.

For any internet connected products the consumer is responsible for ensuring a stable internet connection. In the event of a network failure the consumer will need to address the concern with the service provider. Use of an App is not a substitute for the User's own vigilance in ensuring the product is working to expectation. Use of a Smart Product App is at the User's own risk. To the fullest extent permitted by law Davey disclaims any warranties regarding the accuracy, completeness or reliability of App data. Davey is not responsible for any direct or indirect loss, damage or costs to the User arising from its reliance on internet connectivity. The User indemnifies Davey against any claims or legal actions from them or others relying on internet connectivity or App data may bring in this regard.

Products presented for repair may be replaced by refurbished products of the same type rather than being repaired. Refurbished parts may be used to repair the products. The repair of your products may result in the loss of any user-generated data. Please ensure that you have made a copy of any data saved on your products.

To the fullest extent permitted by law or statute, Davey shall not be liable for any loss of profits or any consequential, indirect or special loss, damage or injury of any kind whatsoever arising directly or indirectly from Davey products. This limitation does not apply to any liability of Davey for failure to comply with a consumer guarantee applicable to your Davey product under local laws and does not affect any rights or remedies that may be available to you under local laws.

For a complete list of Davey Dealers visit our website ([daveywater.com](http://daveywater.com)) or call:

---

## DAVEY

Davey Water Products Pty Ltd  
Member of the GUD Group  
ABN 18 066 327 517

[daveywater.com](http://daveywater.com)

### AUSTRALIA

**Customer Service Centre**  
6 Lakeview Drive,  
Scoresby, Australia 3179  
Ph: 1300 232 839  
Fax: 1300 369 119  
Email: [sales@davey.com.au](mailto:sales@davey.com.au)

### NEW ZEALAND

**Customer Service Centre**  
7 Rockridge Avenue,  
Penrose, Auckland 1061  
Ph: 0800 654 333  
Fax: 0800 654 334  
Email: [sales@dpw.co.nz](mailto:sales@dpw.co.nz)

© Davey is a registered trademark of Davey Water Products Pty Ltd. © Davey Water Products Pty Ltd 2021.

DWP 2138

---

\* Installation and operating instructions are included with the product when purchased new. They may also be found on our website.