

OWNER'S MANUAL

 **PENTAIR**
ONGA®







For the Installation, Operation and Service of the

LSFII

Sand Filter

Should the installer or owner be unfamiliar with the correct installation or operation of this type of equipment you should contact the distributor/manufacture for the correct advice before proceeding with the installation or operation of this product. The pump operator or owner must be provided with this owner's manual.

Cautions and Warnings

	<p>Hazardous Pressure Incorrectly installed or tested equipment may fail, causing severe injury or property damage. Read and follow instructions in owner's manual when installing and operating equipment. Have a trained pool professional perform all pressure tests.</p>
	<p>Turn pump off before changing valve position</p>
	<p>Do not unscrew MPV clamp while pump is running</p>
	<p>All glued fittings and pipe work should be allowed to dry to atmosphere for 24 hours before closing the installation. Failure to do so could cause injury or installation failure.</p>
	<p>The fittings on these filters are constructed of ABS. Some PVC jointing compounds are incompatible with ABS possibly causing failure to the product. Check compound suitability prior to use.</p>

Contents

Cautions and Warnings	1
Contents	2
Specifications	3
Filter Application	4
Installation/ Assembly	6
Operation	7
Start up	8
Service & Maintenance	8
Troubleshooting	11
Replacement Parts	12

Specifications

Model	Product	Filter Area ft ² / m ²	Backwash Flow Rate (LPM)	Maximum Flow Rate (LPM)
LSFII-21-40	Leisuretime II Sand Filter 21" / 40mm MPV	2.1 / 0.2	120	190
LSFII-25-40	Leisuretime II Sand Filter 25" / 40mm MPV	3.2 / 0.3	180	260
LSFII-25-50	Leisuretime II Sand Filter 25" / 50mm MPV	3.2 / 0.3	180	280
LSFII-28-50	Leisuretime II Sand Filter 28" / 50mm MPV	4.1 / 0.38	230	350
LSFII-31-50	Leisuretime II Sand Filter 31" / 50mm MPV	5.4 / 0.5	270	415

Model	A (mm)	B (mm)	C (mm)	D (mm)	Valve port size (mm)	Sand (kg)	Glass (kg)	
							Coarse	Fine
LSFII-21-40	845	535	730	670	40	85	30	60
LSFII-25-40	950	635	835	775	40	145	45	90
LSFII-25-50	985	635	815	731	50	145	45	90
LSFII-28-50	1050	723	960	877	50	200	60	120
LSFII-31-50	1200	800	1085	1002	50	300	90	150

LSFII-21-40 & LSFII-25-40

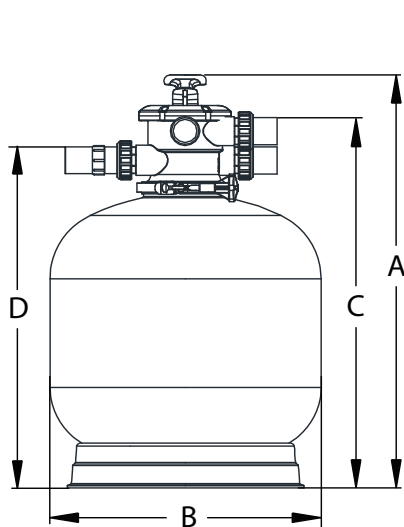

LSFII-25-50 & LSFII-28-50

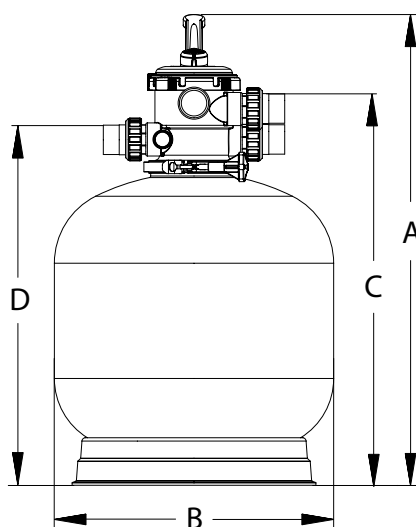

LSFII-32-50

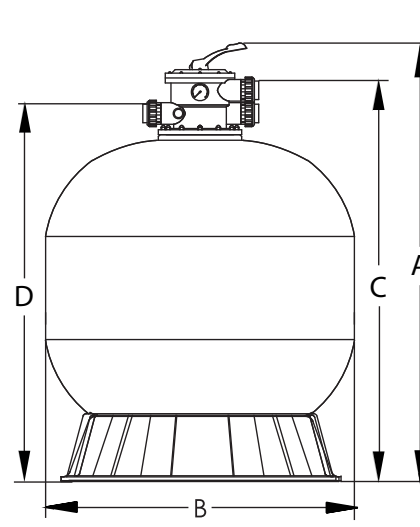

Filter Application - General Information

This filter is designed for use in domestic/residential swimming pool installations with correctly sanitised fresh or salt chlorinated water. Suitable for use with sand, Zelbrite or glass filter media.

1. Locate the filter system as close to the pool as practical.
2. Place the filter on a level stable foundation, preferably a concrete pad or paving. Filter systems loaded with sand and water can exceed 500kg.
3. Position all equipment to provide ease of access for future servicing.
4. Protect the filter and pump from weather and direct sunlight by ensuring that they are properly housed.
5. Ensure there is sufficient space to provide adequate ventilation to electric pump motor.
6. Clean a new pool as well as possible before filling pool and operating filter. Excess dirt and large particles of foreign matter in the system can cause serious damage to the filter and pump.
7. Ensure pump is compatible with filter specifications.
8. For below water level installations ensure isolation valves are installed to reduce risk of flooding.

Installation / Assembly of Internal Components

Installation of filter should be only carried out by qualified personnel. Ensure that the under-drain assembly (hub, laterals & tube) are properly assembled & installed prior to adding filter media (sand).

1. The filter internals comprise of a collector hub and eight (8) laterals, which are supplied packaged seperately with the collector hub and are stored inside the filter tank prior to shipment.
2. Carefully inspect the laterals and hub prior to assembly for any visible defects.
3. Please ensure all laterals are hand tight prior to adding media, as they may have loosened during shipping.

Loading Sand Media

1. To keep sand out off collector assembly, place plastic sand shield over top of collector tube before pouring sand into filter (See diagram below).
2. To support laterals and prevent lateral breakage during loadings, fill tank about half full of water before loading sand.
3. Pour sand into filter, making sure that the sand is of the correct type and quantity for the particular filter model (Refer filter label).

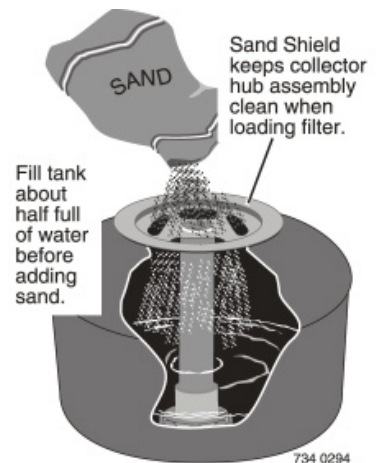

▲ IMPORTANT

Make sure gasket area on top of tank is free of sand before installing valve.

4. Before installing valve, double-check that the correct quantity of sand has been loaded.
5. Remove plastic sand loading shield and keep for future use.

Installation of Multi-port Valve

1. Install o-ring on valve flange; make sure o-ring is clean, and has no nicks, tears, or scrapes and lubricate with silicon based lubricant.
2. Make sure tank and valve flanges are clean and free of sand; put valve on top of tank. Vertical pipe of collector assembly inserts into base of valve.
3. Install clamp; make sure knob is positioned for easy access for filter maintenance. Valve port labelled "Pump" should point toward pump.
4. Tighten clamp knob until clamp ends (under bolt) are 1/4" (6mm) apart. Tap around outside of clamp with a mallet to help seat clamp.
5. Connect pipe from pump discharge to valve port labelled "PUMP"; use union provided. Assemble union as follows for leak free operation:
 - O-ring and sealing surfaces must be clean.
 - Assemble hand tight only (No wrenches).
 - NO pipe compound or teflon tape on unions.

6. Complete all plumbing connections, using 1 1/2" (LSFII-21-40 & LSFII-25-40) or 2" (LSFII-25-50, LSFII-28-50 & LSFII-32-50) pipe to reduce pressure losses as much as possible.
 - Pipe from valve RETURN port to pool return.
 - Pipe from valve WASTE port to waste.
 - Suction piping from pool to trap inlet on pump.
7. System is ready to start up.
8. If you notice a leak around the clamp area after 15-30 minutes of running, repeat steps 3-4.

⚠ CAUTION

If there are leaks from beneath valve/clamp area, STOP PUMP, release all pressure by turning valve handle to 'waste', remove clamp and valve and clean sealing surfaces

Operation

The operation and the positions of valve settings are as follows:

Valve Settings	Function
Filter	Normal filtration and vacuuming; water goes through filter to pool.
Waste	Lowest pool level or drains pool; water bypasses filter, goes to waste.
Closed	Shuts off all flow to filter and pool.
Backwash	Reverses flow for cleaning; water goes through filter to waste.
Rinse	For initial startup cleaning and sand bed leveling after backwash; water goes through filter to waste.
Recirculate	Circulates pool water; bypasses filter.

WARNING: TURN PUMP OFF BEFORE ADJUSTING VALVE

FILTER

WASTE

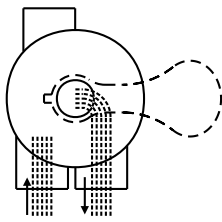

IN FLOW OUT FLOW

WASTE

WASTE

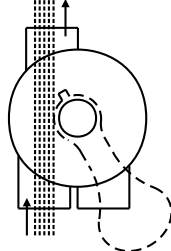

IN FLOW OUT FLOW

CLOSED

WASTE

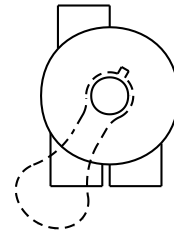

IN FLOW OUT FLOW

BACKWASH

WASTE

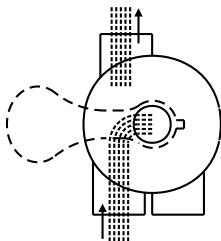

IN FLOW OUT FLOW

RINSE

WASTE

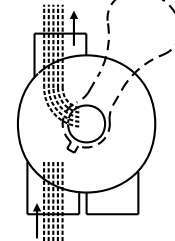

IN FLOW OUT FLOW

RECIRCULATE

WASTE

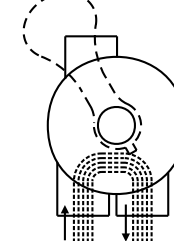

IN FLOW OUT FLOW

Start up

1. Open system valve and make sure pump is filled with water. Make sure pool water level is 2" (50mm) above bottom of skimmer opening.
2. With pump OFF, set valve to 'BACKWASH' position.
3. Start pump, circulating water through filter to waste. NOTE: To prevent pump running dry, be sure water level never drops below bottom of skimmer inlet. Add water to pool if necessary to keep skimmer flooded while back-washing and rinsing.
4. Backwash until water runs clear (1-5 minutes)
5. Stop Pump; set valve to 'RINSE' position.
6. Start pump; run pump for 1 minute. Note: for Zelbrite repeat steps 1 through to 6 three times.
7. Stop pump; set valve to 'FILTER' Position.
8. Filter is now ready for service.
9. Record clean starting filter pressure gauge reading as a reference.
10. For new pools, backwash once a day until pool water is sparkling clear. Backwash when pressure gauge shows 5 to 7 psi (35 to 50kPa) higher than clean starting pressure (refer to step 9).

Service & Maintenance



Hazardous pressure. Stop pump and release all pressure from system before working on filter, valve, or clamp.

General: Wash outside of filter with a mild detergent and water. Rinse off with hose.

▲ IMPORTANT DO NOT use solvents to clean filter; solvents may damage components in system.

Inspect sand/media bed at least once a year to remove foreign material which has not been back-washed out of the system.

NOTE: When the sand/media bed gets hard and crusty on top, remove all the old sand/media and replace it with new sand/media. Alternatively, if the pressure gauge does not return to within 40kPa of clean filter pressure after back-washing it is time to replace the filter media.

Weekly Pool Equipment Inspection

1. Check pressure during operation. When pressure is 5 to 7 psi (35 to 50 kPa) higher than clean operating pressure, backwash filter (see instructions under Startup/Operation, page 12).
2. Except during hot weather with heavy skimmer loads, operating filter 6 to 12 hours per day should be sufficient. Carefully monitor water chemical balance and follow recommendations of your local pool professional.

Water Maintenance

Keep water level at least 2" (50mm) above bottom of skimmer opening. Failure to do so can allow air to enter system, causing pump to lose prime and air to enter filter.

Maintain pH between 7.2 and 7.6 in pool.

⚠ WARNING

To prevent damage to system components, keep water temperature below 38°C at all times.

Vacuum Pool

(Refer cleaner operating manual or consult your local pool professional)

1. Fill vacuum hose by submerging in water from one end to the other.
2. To vacuum, insert hose into skimmer suction manifold or into vacuum line in pool wall. See instructions provided by the pool builder or pool manufacturer. Start pump, making sure it is primed and pumping.
3. After vacuuming, clean pump trap basket to remove accumulated debris, then check filter pressure gauge. If reading is 5 to 7 psi (35 to 50 kPa) higher than initial operating pressure, backwash filter.

Lower or Drain Pool

1. Turn pump 'OFF' ; set valve handle to 'WASTE'.
2. Use Vacuum cleaner hose and head.
3. Start pump; run until pool is lowered to desired level.
4. Turn pump 'OFF' set valve handle to 'FILTER'
5. Start pump.

Multi-Port Valve Service

⚠ WARNING

If valve is leaking during normal operation it will need to be repaired by an authorised Pentair Water service technician.

Valve Removal

⚠ WARNING

Hazardous pressure. Stop pump and release all pressure from system before working on filter, valve, or clamp.

NOTE: If Multi-Port Valve is below pool water level, close suction and discharge valves before disassembly to prevent draining pool.

1. Disconnect piping from pump and pool.
2. Remove clamp.
3. Remove valve from filter top.
4. To re-install valve, follow instructions, BE SURE to follow clamp tightening instructions.

Maintenance

Your new product incorporates moving parts and withstands high velocity water with chemicals in it. Some of these parts will wear in the normal course and use and require checks and maintenance. Performing these checks and maintenance will identify parts that have worn and require repair. replacement before further serious damage is sustained. A small amount of regular care and attention to your pool equipment will help ensure long life and trouble free performance.

Timing	Maintenance	Service
Fortnightly	Check pressure guage. If pressure increase is greater than 20kPa cleaning may be required.	Perform backwash according to instructions.
Three Monthly	Check inlet/ outlet o-rings for leaks.	Isolate Pump, turn power off, clean and grease O-rings or replace if necessary.
Annually	Compare operating pressure of backwashed filter into initial pressure (when new). If using Zeolite, regenerate filter sand. This is important in commercial applications as it aids in the removal of ammonias.	If pressure is more than 30-40kPa different from new filter, a sand change may be required. Add salt to filter sand per supplier. Allow to sit for 24 hours then backwash, rinse and return to filter.

Troubleshooting

Symptom	Remedy
Filter startup pressure high and water flow low	Filter requires backwash- Follow backwash procedure outlined in manual.
	Return line restricted- check for flow at return.
Filter startup pressure low and water flow low	Skimmer basket full of leaves or debris- clear skimmer basket of all foreign matter and debris.
	Pump strainer lid not sealed correctly. - Refer to pump owners manual for correct procedure for sealing strainer lid correctly.
	Pool water level is too low. - Fill pool correct level.
	Pool impeller blocked- call an authorised service agent to service pump.
Short filter cycles	Filter dirty- filter not backwashed for long enough period.
	Replace media (sand or Zelbrite)
	Algae present in Pool water. - DONT RUN FILTER WITH LIVE ALGAE IN POOL. Check the chemical condition of the pool water and refer to Pool Water Chemical Treatment. Note: Incorrect chemical treatment will greatly shorten filter life.
Leaking from filter tank joint	Tank o-ring dirty
	O-ring incorrectly fitted- or pinched
	Clamp band not correctly fitted

Replacement Parts

LSFII-21-40 & LSFII-25-40

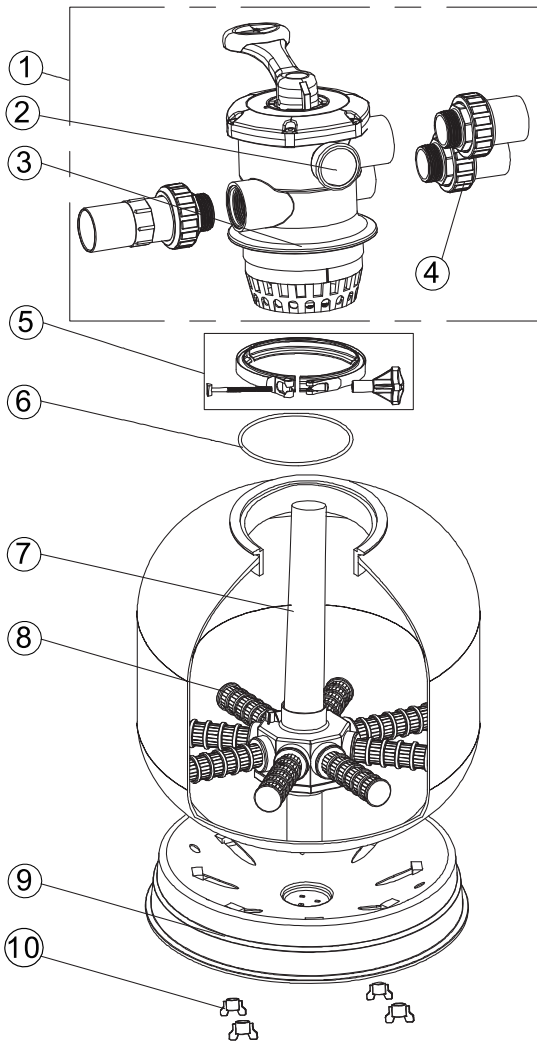

LSFII-25-50 & LSFII-28-50

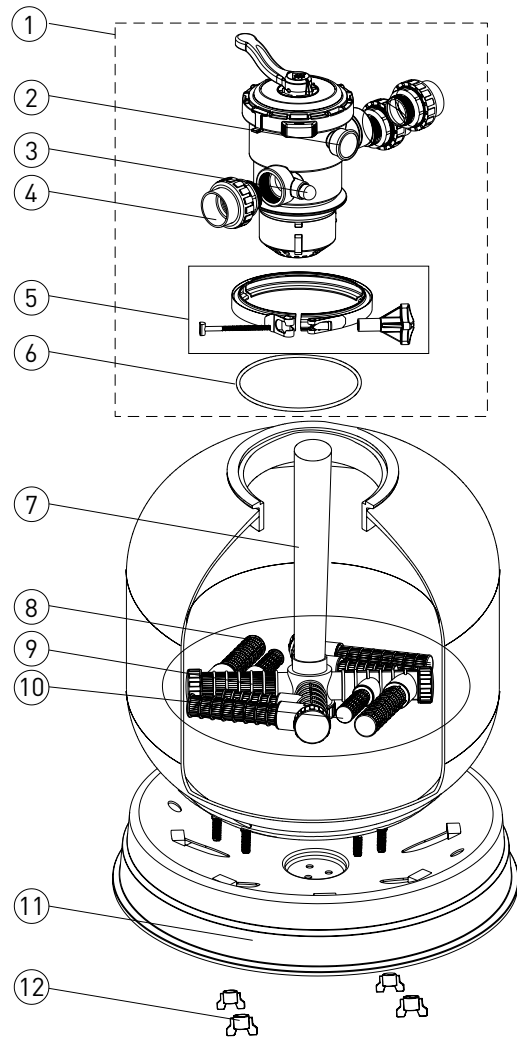

Item	Part No.	Description
LSFII-21-40 & LSFII-25-40		
1	88280150	1.5" Clamp Type Multiport Valve
2	89280705	Pressure gauge Assembly
3	89280108	1.5" union with sight glass with O-ring
4	89280109	1.5" union
5	89010126	Stainless Steel Clamp Assembly
6	02011134	O- Ring for Filter Neck
7	89010122	LSFII- 21- 40 Standpipe with hub
	89010123	LSFII- 25- 40 Standpipe with hub
8	01172008	Laterals (126mm)
9	01112074	LSFII- 21- 40/ LSFII- 25- 40 Filter Base
10	01181052	Fastener for Filter Base

Item	Part No.	Description
LSFII-25-50 & LSFII-28-50		
1	88281506F	2" Top Mount Valve
2	89280705	Pressure gauge Assembly
3	89280104	Sight glass assembly
4	89280110	2" union (3 required)
5	89010126	Stainless Steel Clamp Assembly
6	02011134	O-ring for Filter Neck
7	89010124	LSFII-25-50 Standpipe with hub
	89010125	LSFII-28-50 Standpipe with hub
8	01172010	Laterals (185mm) (4 required)
9	89012516	Laterals bracket (4 required)
10	01172007	Laterals (115mm) (4 required)
11	01112074	LSFII-25-50 Filter Base/ LSFII-28-50 Filter Base
12	01181052	Fastener for Filter Base (4 required)

Replacement Parts

LSFII-32-50

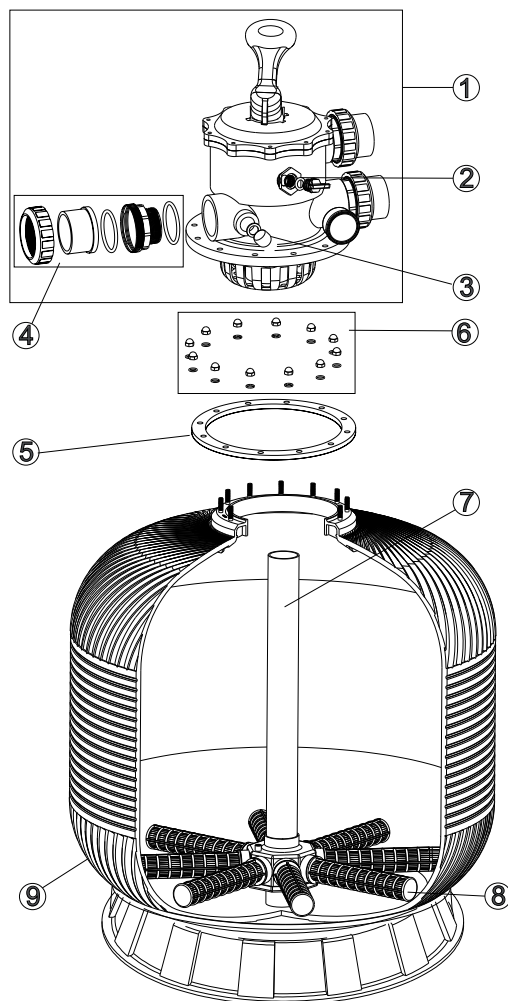

Item	Part No.	Description
LSFII-32-50		
1	88280351	2" Top Mount Valve
2	89280705	Pressure guage Assembly
3	89280813	Sight glass assembly
4	89280110	2" union (3 required)
5	02011126	Filter Neck Gasket
6	02011134	MB Nut + MB Washer (12 required)
7	89010122	LSFII- 32- 50 Standpipe with hub
8	01172008	Laterals (185mm) (8 required)
9	01112074	LSFII- 32- 50 Filter Tank with Base

Replacement Parts

USED ON

MODELS:

LSFII-21-40

LSFII-25-40

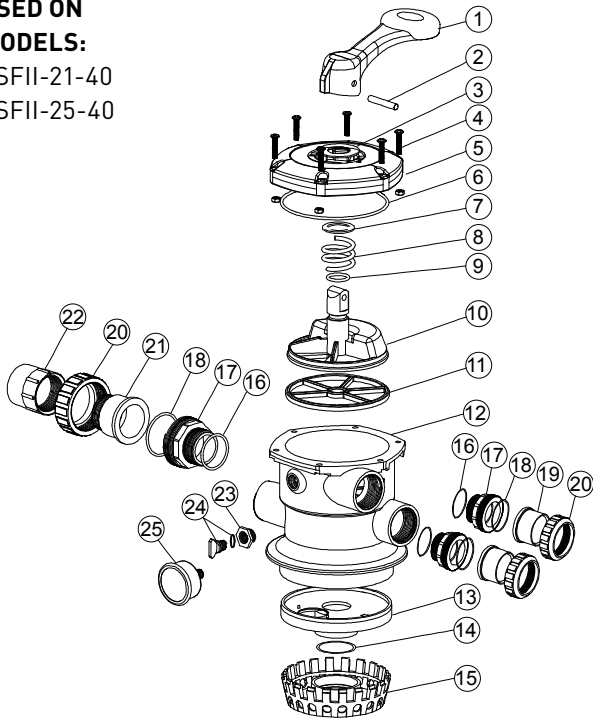

Item	Part No.	Description
MULTIPOINT 1-1/2 IN. VALVE		
1	800770	MPV Handle Assembly (Includes 1, 2 & 3)
2		Pin for Handle
3		Washer for Handle
4		M6 x 25 Screw with Nut for Camber Lid
5	800771	Lid Kit (Includes 4,5 & 6)
6	800774	O-Ring for 1.5" Valve Lid
7		Washer for Spring
8		Spring for 1.5" Top Mount Valve
9		O-Ring for 1.5" Valve Rotor
10	800772	Rotor and Gasket Kit (Includes 7,8,9,10 & 11)
11	800775	Spider Gasket
12		1.5" Top Mount Valve Bottom Body Clamp (Black)
13		1.5" Diffuser
14		O-Ring for 1.5" Union
15		1.5" Top Mount Valve Over Drain Diffuser
16	02020013	O-Ring for Union
17		1.5" Connector (White)
18	02011003	O-Ring for 1.5" Union
19		1.5" Union (A) (White)
20	89280109	1.5" Union Kit (Includes 16, 17, 18, 19 & 20)
21	01041002	1.5" Union Sight Glass (Inc 16, 17, 18, 20, 21, 22)
22		
23		Connector for pressure gauge/ stopper
		O-Ring
24		Drain Plug with O-Ring
25	89280705	Oil Pressure Gauge Kit (Inc 23, 24 & 25)

USED ON

MODELS:

LSFII-25-50

LSFII-28-50

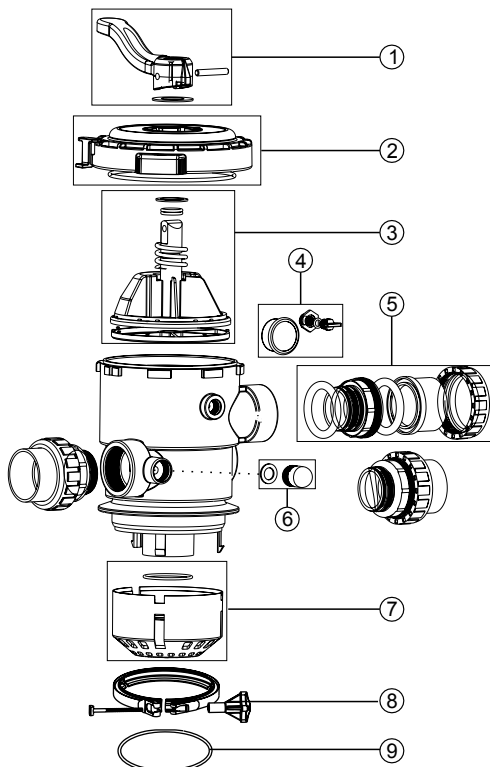

Item	Part No.	Description
MULTIPOINT 2 IN. VALVE		
1	89280702	MPV Handle Assembly
2	89280809	Lid Assembly 2" MPV
3	89280810	Seal Rotor and Gasket Kit 2" MPV
4	89280705	Pressure gauge Assembly
5	89280110	2" UNION
6	89280104	Sight glass assembly
7	89280811	Diffuser Assembly 2"
8	89010126	Stainless Steel Clamp Assembly
9	02011134	O-Ring for Filter Neck
NOT SHOWN		
	02010003	O-Ring Lid
	07020496	Decal Lid
	02011005	O-Ring Stem Pipe

Replacement Parts

USED ON
 MODELS:
 LSFII-32-50

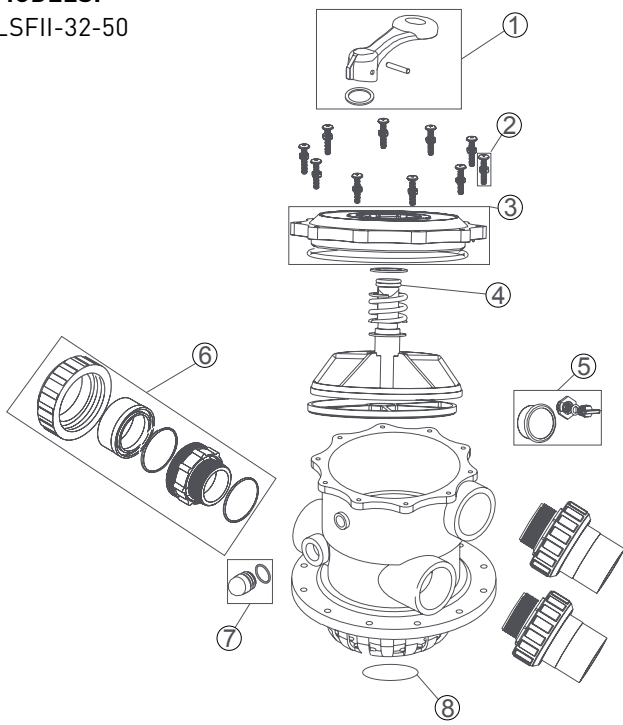

Item	Part No.	Description
MULTIPORT 2 IN. VALVE		
1	89280707	MPV Handle Assembly
2	89280301	M6*32 Screw with Nut
3	89280816	Lid Assembly 2" MPV
4	89280817	Seal Rotor and Gasket Kit 2" MPV
5	89280705	Pressure gauge Assembly
6	89280110	2" Union
7	89280813	Sight glass assembly
8	02011005	Diffuser Assembly 2"

Notes

Notes

Notes

LSFII

Sand Filters

IMPORTANT

Please attach your sales invoice/docket here as proof of purchase should warranty service be required.



Purchased from:.....

Purchase date: Serial No.: Model No.:

**Head Office
Pentair AU/NZ:**

1-21 Monash Drive
Dandenong South,
VIC 3175

National customer service:	Phone: 1300 137 344
	Fax: 1800 006 688
National dealer locator:	Phone: 1800 664 266
Email:	au.sales@pentair.com
Web:	www.pentairpool.com.au

Distributed in NZ By:



Freephone 0508 634 341

7 Monier Pl, Mt Wellington, Auckland 1060, New Zealand

© Information contained here-in remains the property of Pentair Australia Pty Ltd. Any reproduction, display, publication, modification or distribution is strictly prohibited without the prior written permission of Pentair Australia Pty Ltd.

Disclaimer:

Every endeavour has been made to publish the correct details in this document. No responsibility will be taken for errors, omissions or changes in product descriptions, specifications. Pentair Australia reserves the right to change specifications.

L300284-A0717