



TINY SUB STAINLESS STEEL SUBMERSIBLE PUMP

Features:

- Strong and durable 304 stainless steel construction
- Double mechanical seal
- Pump Side – silicon carbide
- Motor side – Carbon/Silicon carbide
- Top discharge
- Float switch option for automatic operation
- 6m power lead
- Maximum liquid temperature: +40°C
- Built in thermal overload

DAVIES TINY SUB SERIES SUBMERSIBLE

MODEL	HP	KW	PHASE	VOLTS	FLOAT SWITCH
TS250	0.25	0.18	1	230	No
TS250A	0.25	0.18	1	230	Yes
TS300	0.33	0.25	1	230	No
TS300A	0.33	0.25	1	230	Yes



TECHNICAL DATA

PERFORMANCE DATA

TS Series

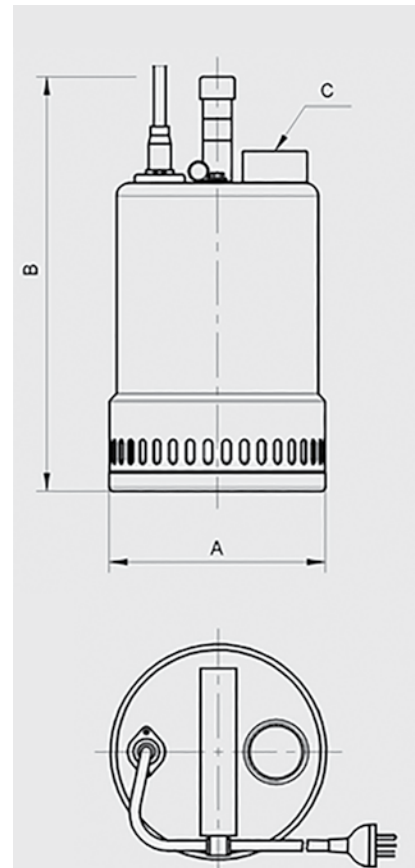
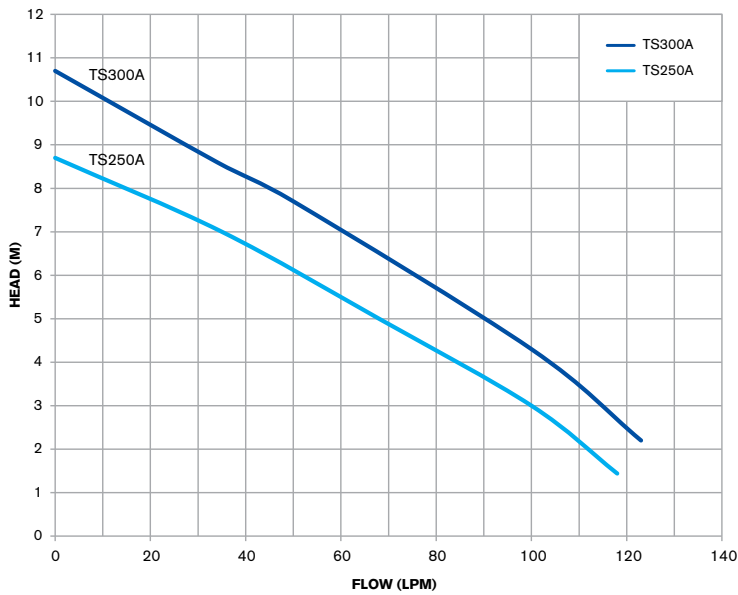

CONSTRUCTION DETAILS

ITEM	MATERIAL	
Outer casing	304 S/S	
Impeller	304 S/S	
Shaft	304 S/S	
O Rings	Buna-N	
Mechanical seal	Pump Side	Silicon Carbide - Silicon Carbide
	Motor Side	Silicon Carbide - Carbon
Cord	Neoprene - 6M	
Insulation	Class B	
Protection	IP68	

DIMENSIONS AND WEIGHT

MODEL	A	B	C	WEIGHT (KG)
TS250	130	280	1 1/4"	6
TS300	150	290	1 1/4"	7

For your nearest dealer please contact Argon Distributors: 0508 634 341

While every endeavor has been made to publish the correct details, no responsibility will be taken for errors, omissions or changes in product specifications. Davies pumps and the 'dp' logo are registered trademarks of Argon Distributors.