

XF92, XF171, XF221 & XF192

Model Numbers: 71401, 71101, 71201 & 71301

DEPEND ON
DAVEY



Also available in 110 or 220 volt 60Hz single phase.

TRANSFER PUMPS

PRODUCT DESCRIPTION

Robust & compact, 1 or 2 stage centrifugal pumps with corrosion resistant componentry and driven by a TEFC motor. Designed for total head duties to 33m and flows to 225 lpm.

APPLICATIONS

Ideal for pumping clean, nonvolatile liquids without fibres or solids in such applications as:-

- Irrigation
- Aquaculture
- Water transfer
- Washing systems
- Hydroponics

FEATURES & BENEFITS

Davey manufactured TEFC IP55 motor is corrosion resistant and resists low pressure jets of water, dust and dirt for long service life in arduous conditions.

Closed vane corrosion proof impellers with full length "D" drive for positive, robust impeller drive.

Motor and pump are designed for frequent starts providing a long and reliable working life.

Pump shafts (and casing on two stage models) are manufactured from quality corrosion resistant stainless steel for long service life when pumping less than perfect water.

Every pump is performance and pressure tested in our factory to ensure quality and reliability.

All models come fitted with a 2m power lead with 10 amp Australian three pin plug for ease of connection to power supply.

High quality mechanical shaft seal for long life and reliability.

OPERATING LIMITS

	XF92	XF171	XF221	XF192
Capacities to	98 lpm	175 lpm	225 lpm	190 lpm
Max. Total Head	28m	17m	20m	33m
Max. Suction Head	7.0m	7.5m	7.5m	7.5m
Min./Max. Water Temperature	1°C/50°C			
Max. Ambient Temperature	50°C			
Inlet Size	1" BSP(F)			
Outlet Size	1" BSP(F)	1" BSP(M)	1" BSP(M)	1" BSP(F)

FEATURES & BENEFITS

Easy to service design for shorter downtime if or when service is required.

Permanently split capacitor design motor for reliable starting even in low voltage circumstances.

Double contact C3-HTG sealed bearings for quieter running and longer life.

In-built automatic-reset thermal overload protection embedded in the motor for quick response to motor overloading. Motor overloading can be the result of extreme ambient temperature, high or low voltage (beyond specification), pump blockage and / or pumping fluids heavier than fresh water (eg sea water).

Plastic feet used on motor shell for long life in poorly drained installations.



TECHNICAL SPECIFICATIONS

MATERIALS OF CONSTRUCTION

PART	MATERIAL
Impellers	Glass filled polycarbonate
Lock nut	304 stainless steel
Pump casing	Glass filled noryl (XF171&XF221) 304 stainless steel (XF92&XF192)
Clamp band	304 stainless steel
Pump shaft	304 stainless steel
Suction cover	Glass filled noryl
Seal ring (stationary)	Ceramic
Seal ring (rotating)	Carbon
Seal spring	304 stainless steel
Orings	Nitrile rubber
Diffusers	Glass filled noryl
Blanking ring (XF92 & XF192)	Glass filled noryl
Spacer	Glass filled nylon
Priming plug	Glass filled noryl
Motor shell	Marine grade aluminium
Shell finish	Baked polyester

ELECTRICAL DATA

	XF92	XF171	XF221	XF192
Supply voltage	220-240V ±6%			
Phase	Single			
Supply frequency	50Hz			
Speed	2,850rpm			
Full load current	3.7A	2.8A	4.5A	5.2A
Locked rotor current	12.0A	12.0A	18.0A	18.0A
Input power (P ₁)	0.84kW	0.78kW	1.05kW	1.15kW
Output power (P ₂)	0.58kW	0.53kW	0.70kW	0.80kW
Enclosure class	IP55			
Insulation class	Class F			
Starting	P.S.C.			

Special Models

XF models are available in a number of alternate voltages and incorporating special features including:

- 110 volt 60Hz
- 220 volt 60Hz
- Thermotection pump over temperature protection
- 316SS casing for XF92 & XF192 models
- Silicon Carbide Seals
- Dog Spa Model

For information of these options contact Davey at the appropriate address shown below.

INSTALLATION & PRIMING

- Installations with suction lift require a good quality foot valve to avoid loss of prime
- To prime, fill pump body and suction line through priming plug hole located above suction inlet and replace plug

This literature is not a complete guide to product usage. Further information is available from your Davey dealer, Davey Customer Service Centre and from the relevant product Installation and Operating Instructions. This data sheet must be read in conjunction with the relevant product Installation and Operating Instructions and all applicable statutory requirements. Product specifications may change without notice. © Davey is a registered trademark of Davey Products Pty Ltd. © Davey Products Pty Ltd 2001.

DEPEND ON
DAVEY

Davey Products Pty Ltd

Member of the GUD Holdings Ltd Group
ABN 18 066 327 517
Head Office and Manufacturing
 6 Lakeview Drive,
 Scoresby, Australia 3179
 Ph: +61 3 9730 9222
 Fax: +61 3 9753 4100
 Website: www.davey.com.au
Customer Service Centre
 Ph: 1300 367 866
 Fax: 1300 369 119
 E-mail: sales@davey.com.au
Interstate Offices
 Sydney - Brisbane - Adelaide
 Perth - Townsville

International

6 Lakeview Drive,
 Scoresby, Australia 3179
 Ph: +61 3 9730 9121
 Fax: +61 3 9753 4248
 E-mail: export@davey.com.au

Germany

Kantstrasse 47,
 04275 Leipzig
 Ph: +49 341 301 0412
 Fax: +49 341 301 0413
 E-mail: akrenz@daveyeurope.com

New Zealand

2 Rothwell Avenue,
 North Harbour, Auckland 1330
 Ph: +64 9 914 3680
 Fax: +64 9 914 3685
 Website: www.daveynz.co.nz
 E-mail: sales@daveynz.co.nz

USA

Davey Pumps Inc.
 1005 N. Commons Drive
 Aurora, Illinois 60504
 Ph: +1 630 898 6976
 Fax: +1 630 851 7744
 Website: www.daveyusa.com
 E-mail: sales@daveyusa.com

HYDRAULIC PERFORMANCE

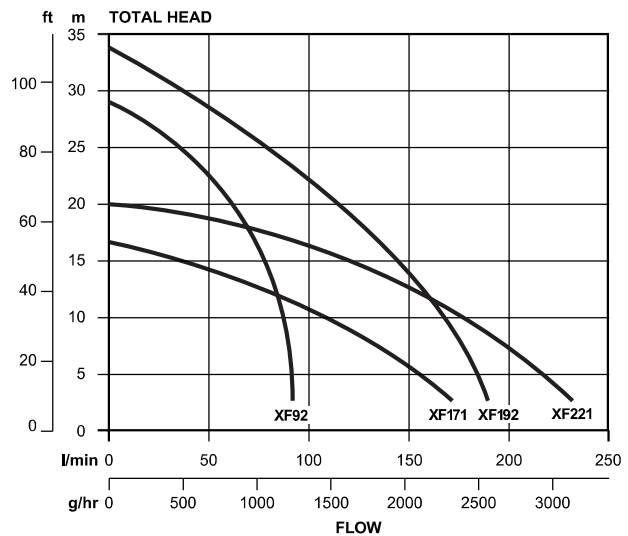

DIMENSIONS

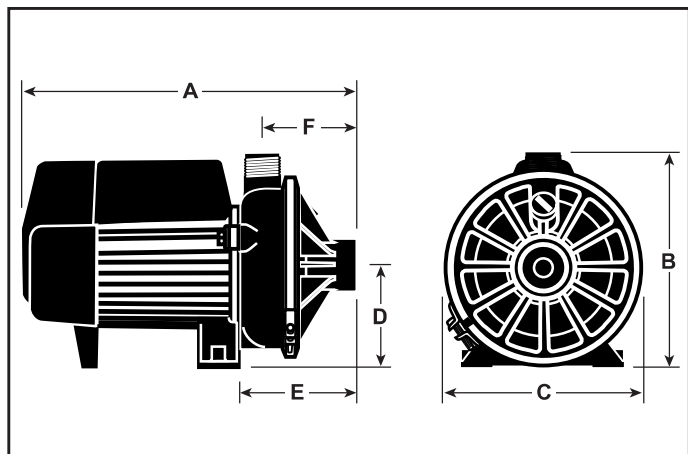

MODEL	A	B	C	D	E	F	Mounting Holes Dia.	Inlet B.S.P.	Outlet B.S.P.	Net Weight (kg)
XF92	325	220	195	100	125	100	10 @ 140 centres	1" F	1" F	7.2
XF171	325	215	193	100	126	100		1" F	1" M	6.7
XF221	350	215	193	100	126	100		1" F	1" M	8.3
XF192	350	220	195	100	125	100		1" F	1" F	8.8

All dimensions in mm unless otherwise stated.



Visit Davey Pumps on-line for further information
www.davey.com.au