

LORENTZ S1-700 pump system

Description

The **LORENTZ S1-700** pump system is a high efficiency pump system designed to pump water using solar power.

The system has an all plugged design for simple customer self installation. All equipment is rated for outdoor use. The system consists of a submersible centrifugal pump attached to a high efficiency brushless ECDRIVE motor. The system controller digitally controls the motor and monitors the system operation. Inputs are provided for connection of accessories for system automation (dry run protection, tank full switch or remote tank switch).

Features

- High-efficiency ECDRIVE DC brushless motor and robust centrifugal pump
- System controller with plugged connections
- Integrated MPPT
- Controller with Bluetooth® connectivity for local configuration and control
- Simple S-Connect app for speed control, timers and extended trouble shooting

Technical data

Pump system	S1-700 CST-2-10	S1-700 CST-4-6
Max. flow	4.8 m ³ /h [20 US gpm]	9.4 m ³ /h [40 US gpm]
Max. head	40 m [130 ft]	25 m [80 ft]

S1-700 controller data

Input (DC)	
Max. voltage (Voc)	220 V DC
Operating voltage	60...220 V DC
Max. current (DC)	8 A
Max. PV short circuit current (Isc)	30 A
Output (DC)	
Rated voltage	100 V EC PWM 3-ph
Max. voltage	220 V EC PWM 3-ph
Max. frequency	220 Hz
Max. continuous current	8 A
Max. continuous power	750 W [1 hp]
Casing	
Enclosure	IP 68
Protective class	I
Sensor inputs	Dry run protection - Tank full switch or Remote Tank Switch
Casing material	Cast aluminium and polycarbonate
General	
CONNECTED App	LORENTZ S-Connect
Pollution degree classification	3
Max. altitude rating	2000 m [6560 ft]
Overvoltage category input/output	OVC II
Controller operating temperature	-30 ... +45 °C [-22 ... 113 °F]
Protection against	Overtemperature, overvoltage, overcurrent, short circuit, reverse polarity

S1-700 controller dimensions and weights

W1	212 mm [8.3 in]
W2	175 mm [6.9 in]
D1	86 mm [3.4 in]
D2	34.5 mm [1.4 in]
E1	6.4 mm [0.25 in]
H1	236 mm [9.3 in]
H2	249 mm [9.8 in]
Net weight	2 kg [4.4 lb]

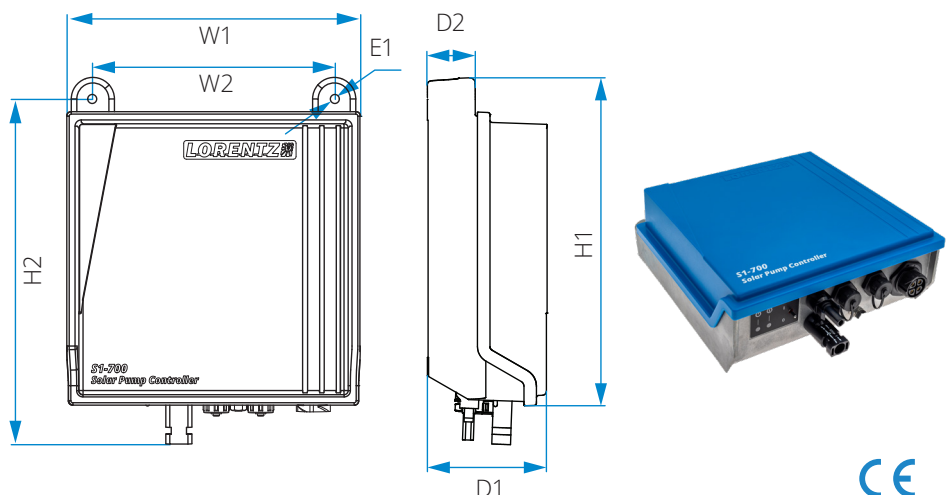

Pump end data

Pump model	CST-2-10	CST-4-6
Pump type	Centrifugal	
Pump outlet size	1 1/4"	1 1/2"
Type of connection	Rp or NPT available	
Min. borehole diameter	100 mm [4 in]	
Max. pump end efficiency	50%	51 %
Housing material	EN 1.4301 [AISI 304]	
Impeller material	Polymer	
Water temp. range	0... +50 °C [32 - 122 °F]	

Motor ECDRIVE data

Rated power (P2)	0.7 kW [0.9 hp]
Motor speed	900 ... 3300 rpm
Insulation class	F
Enclosure class	IP 68
Max. motor efficiency	87 %
No. poles	8
Max. submersion	50 m [164 ft]
Max. water temperature	50 °C [122 °F]
Shaft extension and coupling	NEMA Standard
Motor material	EN 1.4301 / 1.4404 [AISI 304 / 316]
Length of cable	15 m [50 ft]
Cable size	4 x 3 mm ² [AWG 13]
Cable plug	4-pin male

Pump with motor dimensions and weights

	CST-2-10	CST-4-6
A	725 mm [28.5 in]	572 mm [22.5 in]
B	154 mm [6.1 in]	154 mm [6.1 in]
C	571 mm [22.5 in]	418 mm [16.4 in]
D	96 mm [3.7 in]	96 mm [3.7 in]
E	99 mm [3.9 in]	99 mm [3.9 in]
S	1 1/4"	1 1/2"
Pump end net weight	8.5 kg [18.7 lb]	7.9 kg [17.4 lb]
Motor net weight	4.2 kg [9.9 lb]	

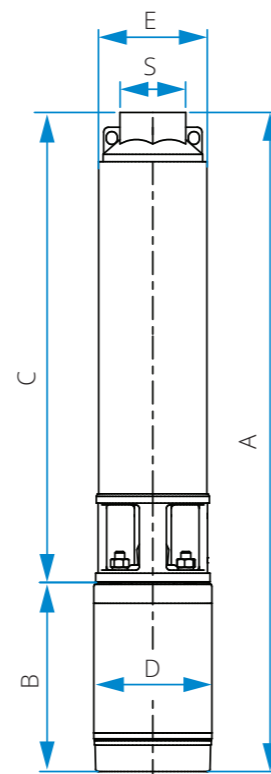

Performance range

S1-700 pump system CST-2-10

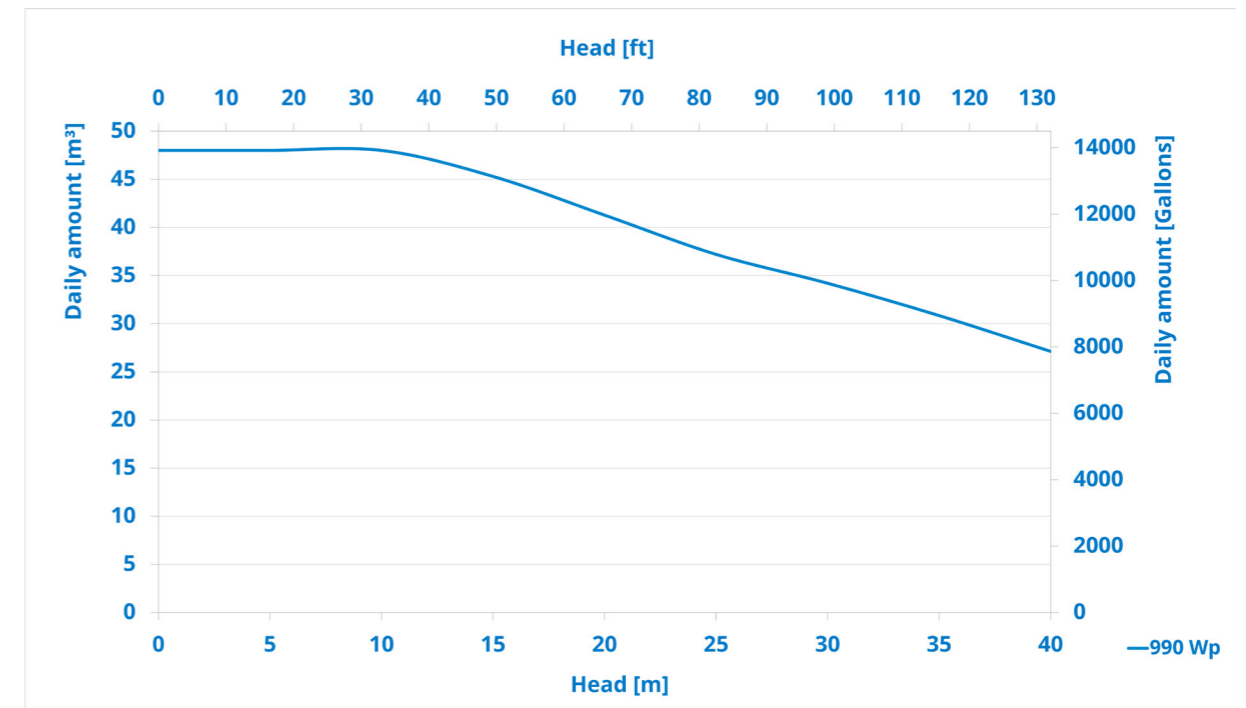

S1-700 pump system CST-4-6

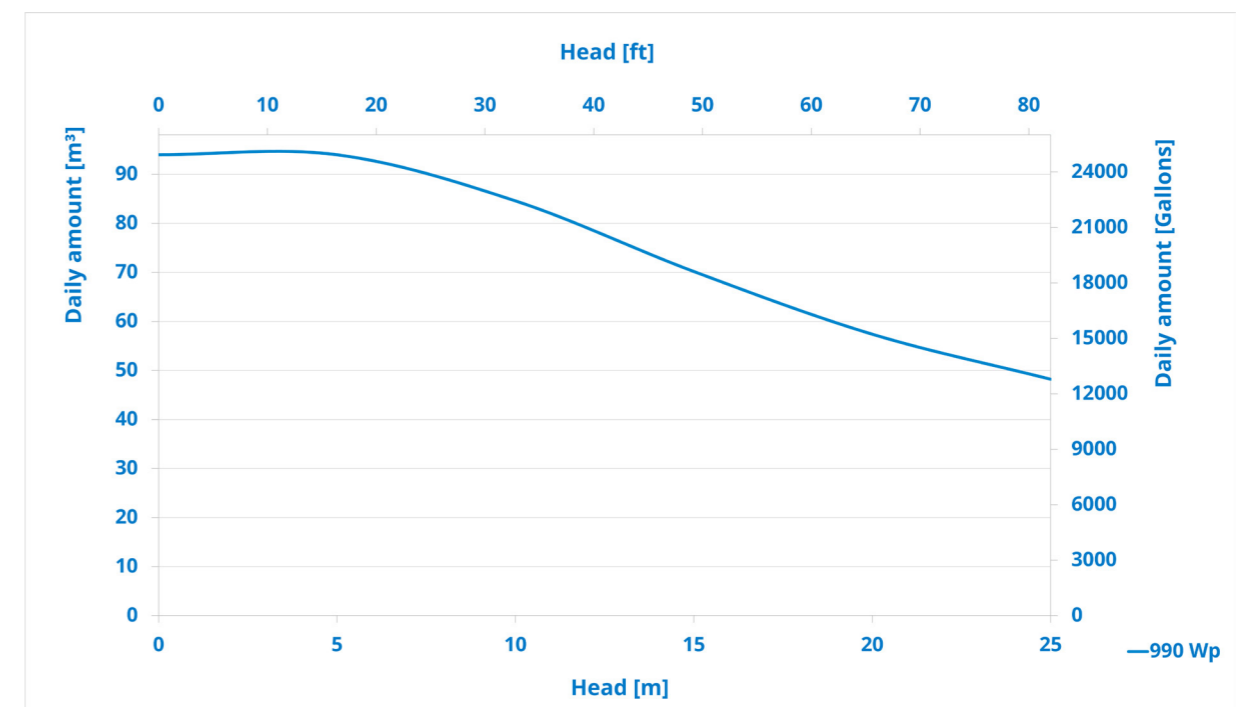

LORENTZ S-Connect App

With LORENTZ S-Connect App easily configure and control your **S1-700** pumping system via Bluetooth® connectivity locally.

- Download it for free on Android™ devices from the Google Play Store or on iOS devices from the App Store.
- Connect to your pumping system and access multiple functions such as: Control and measurement of daily/weekly flow, speed, power, performance of connected sensors, timers setting, detailed troubleshooting scheme.

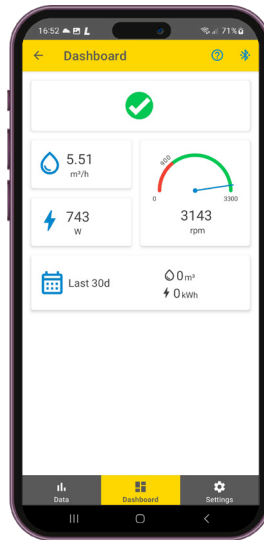

Order and packaging information

Thread type		Rp	NPT
S1-700 pump system	CST-2-10	01-001150	01-001160
	CST-4-6	01-001170	01-001180
Box content		1 x S1-700 controller	
		1 x pump with motor (includes 15 m [50 ft] cable)	
		1 x manual	
Packed gross weight	CST-2-10	18 kg [40 lb]	
	CST-4-6	17 kg [37 lb]	
Packaging dimensions [LxWxH]		1080 x 265 x 130 mm [42.5 x 10.4 x 5.1 in]	
Packed volume		0.037 m³ [1.3 ft³]	
Systems per pallet		21	
Storage temperature		-20 °C... +65 °C [-4 °F...+149 °F]	

